

CNC Grinding Center Model Eclipse

Compact Precision Grinding Center
with dual Grinding Spindles



Grinding Power and Precision in a small footprint

The Model Eclipse extends the TTB range with a compact and innovative Machine

Kinematiks – a two-spindle machine for increased Precision

Highlights of the machine:

In addition to the very small footprint and 4-station wheel changer, the Eclipse Grinding Center features a 2nd grinding spindle for finishing the final tool-geometry.

Since the spindle 2 wheel package is not being changed during the grinding cycle, there will not be any random inaccuracies.

The grinding spindle 1 has an automatic (or manual) wheel changer and is primarily for roughing operations.

Further features:

The workpiece spindle has dual functionality: it can be used as a positioning axis or a free-turning spindle (used when cylindrical grinding or dressing). The B axis can be equipped with worm-gear or direct drive. The X-Z axes are backlash-free as a result of hydraulic compensation.

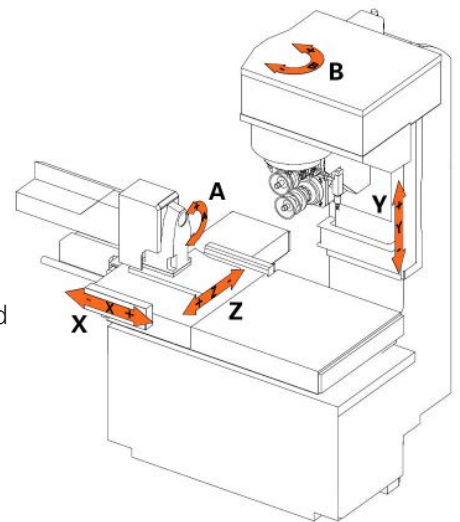

Easy Setup for Resharpener or Grinding Tools of high Quality

The optimal Machine for continuous production, but still with easy and flexible set-up.

Flexible Software, fast changeover of the wheel packages, open access to the tool loader and a highly reliable collet clamping system... resulting in a machine that is an extremely setup-friendly production unit.

Setup of the machine

Particular attention has been paid to the accessibility of the machine. The well-tested components allow fast changeover of tool production. The ergonomic designed operator's panel is height-adjustable.

The Robot and 3 loading pallets are located within the machine footprint, keeping it floor space friendly. The double grippers (for blanks and finished tools) can clamp diameters 1 to 16mm without involving the operator.

The tool probe is part of the standard equipment. The grinding wheels can be dressed and automatically probed in the machine (options).



Innovative Automation for Productivity and Flexibility

Fully automatic grinding on a small footprint thanks to the smart integration of the Robot within the machine cabinet.

Loader with high capacity

Fast and flexible loading are possible by the use of a modern robot. For the diameter range of 1 to 16mm, up to 750 blanks can be loaded. The double grippers (for blanks and finished tools) can clamp diameters 1 to 16mm without involving the operator. The separation door between the loader and the grinding area moves together with the robot.

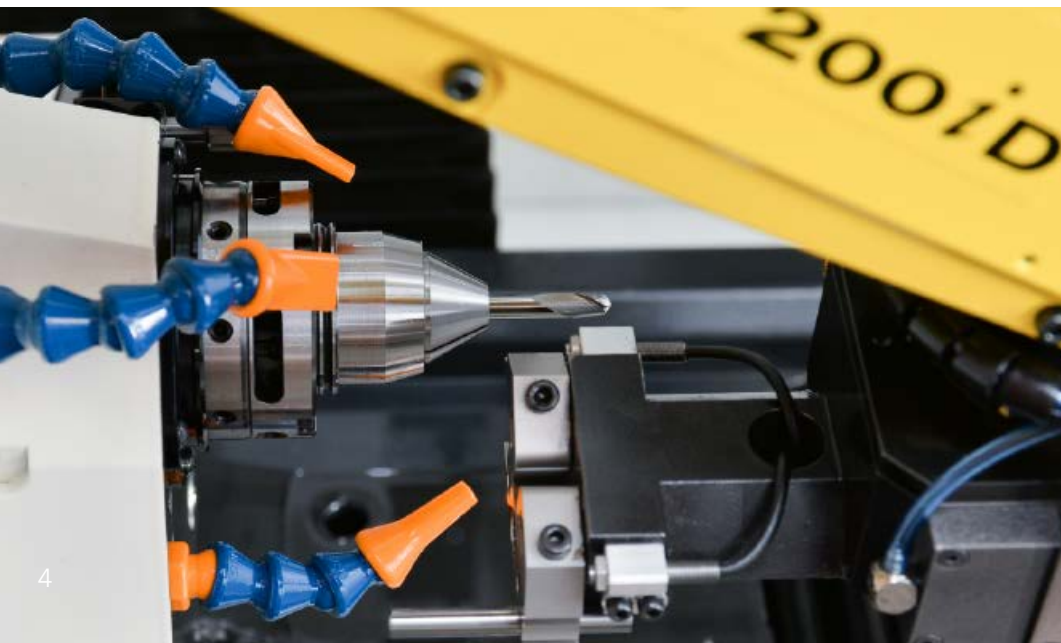

Optimisation of grinding and Flexibility by selected Accessories

TTB can offer special peripheral equipment and accessories

- Coolant filter and supply pump units
- Chillers
- Oil mist filtration systems
- Fire protection systems
- Steady rest for support of tools
- Special loading units
- Grinding Wheel probing
- Tool probing

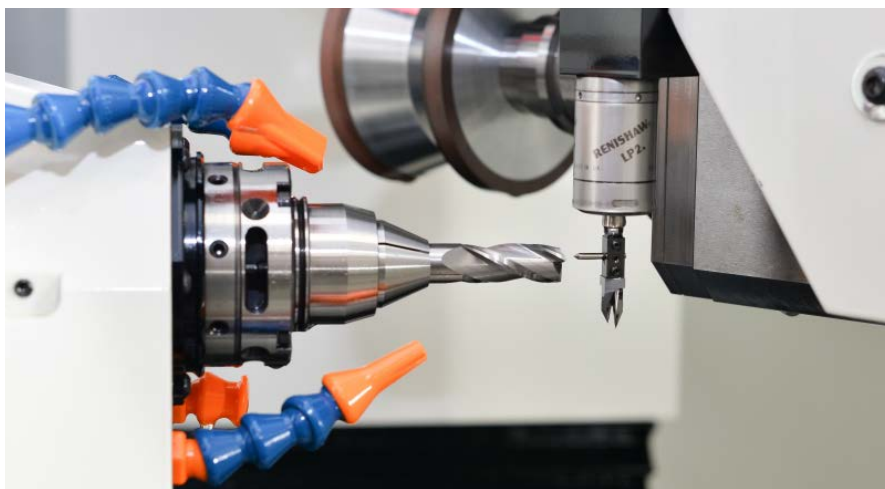
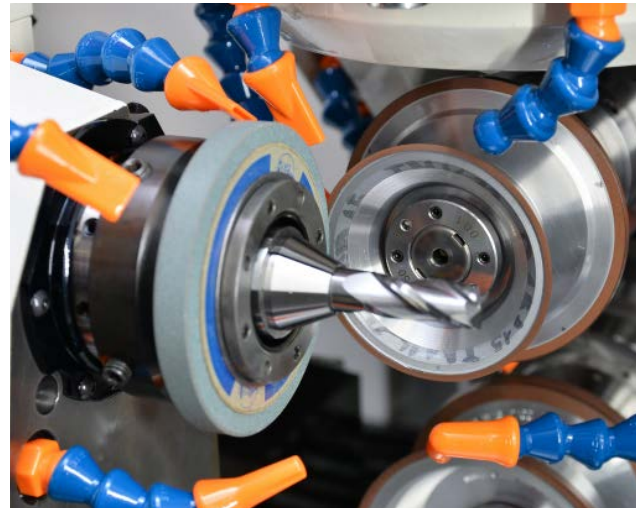

Optimal solutions for your applications

Steady Rest Eclipse

The automatic steady rest is demanded for tools having a grinding length ratio greater than 10 to 15 times the diameter. The installation and setup require only a few, easy steps. The steady rest is placed onto the cross table. The V-block bushings or half-round support bushings can be aligned to the taper angle of the tools.

Wheel-Set Changer

The wheel-set changer holds up to 4 wheel-sets and one blind arbour. The wheel-sets are programmed in the Numroto grinding program and automatically exchanged into Spindle 1. A blind plug adapter protects the spindle taper from contamination when not in operation. A protective enclosure keeps all grinding wheel packages protected from oil and unwanted contamination.

Machine Control

The Model Eclipse is equipped with the CNC control Num. This allows customizing the different grinding strategies, as well as enhancing the existing Programmers and Operators Know-How.

NUMROTOplus® Programming System

NUMROTOplus® with 3D grinding simulation and collision control

- Standard and special tools are programmed easily with the flexible and versatile Software NUMROTOplus®
- Guarantee of constant innovation by continuous Software Updates on up-to-date PCs
- Extraordinary programming variety with enhanced databases for Tools, Technology and Wheel Packages
- Free Software Updates are guaranteed over the whole life-cycle of the machine



Technical Specifications

Tool data	
Min. diameter from solid material	0,1 mm
Max. diameter from solid material	12,7 mm
Max. diameter for resharpening	30 mm
Max. grinding length	200 mm
Longitudinal X-axis	
Travel range	530 mm
Feed rate	0 - 15 m/min
Cross slide Z-axis	
Travel range	320 mm
Feed rate	0 - 15 m/min
Vertical Y-axis	
Travel range	400 mm
Feed rate	0 - 15 m/min
Double grinding wheel head B-axis	
Swivel angle in horizontal plane	240 deg.
Max. Grinding wheel diameter	100 mm
Grinding spindles speed	up to 24'000 rpm
Roughing Spindle S1 automatic clamping	HSK - E50
Finishing Spindle S2 manual clamping	HSK - C50
Power grinding motor 1 (S6)	9,0 kW
Power grinding motor 2 (S6)	4,5 kW
Number of grinding wheel sets	
Wheel sets for spindle S1 in automatic wheel changer	4
Wheel sets for spindle S2, manual clamping	1
Work head A-axis	
Clamping system	W25, W20, B15 Hydraulic collet
Clamping diameter range	1 - 25,4 mm
Max. Rotary speed for cylindrical grinding	0 - 1500 rpm
CNC Control	
NUM Software	NUMROTOplus
Dimension of machine (L x W x H)	
	200 x 215 x 210 cm
Weight	
	3800 kg

Subject to technical change without notice.
The brochure shows also optional equipment.

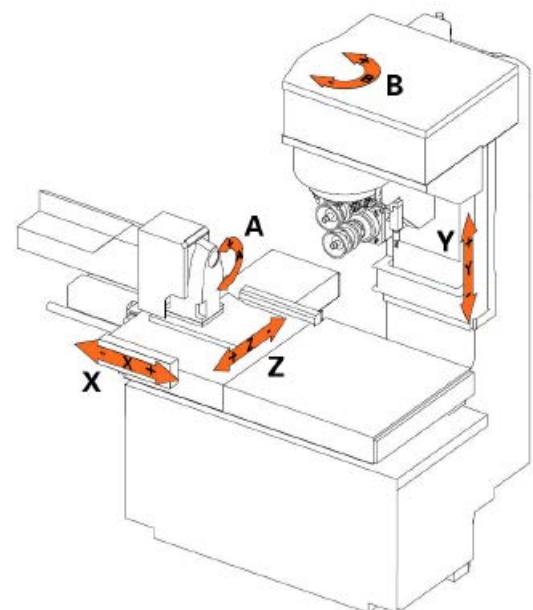
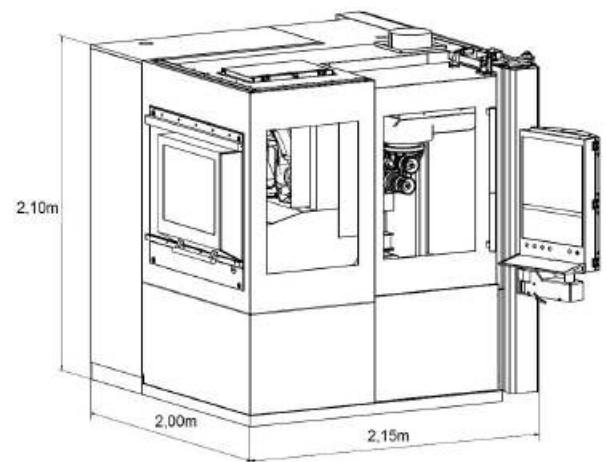



TTB Engineering SA
Via Industria 9
CH-6826 Riva S. Vitale
Tel (+41) 91 / 640 20 30
Fax (+41) 91 / 630 50 49
www.ttb-eng.com
info@ttb-eng.com

